



REFERENCE:
L1322

MARKER LAMP 6LED
12/24V DARK RED

WARNINGS FOR THE USER:

- Do not look directly into the light - it may cause damage or even loss of vision.
- Install only in specialized workshops or professional services.
- Use in open space only.
- Use in accordance to the purpose.

INSTALLATION INSTRUCTIONS:

- It should be used exclusively in accordance with intended use.
- Mount exclusively in specialized workshops.
- The connection between the lamp and vehicle's installation should be isolated with heat-shrink tube or alternatively with isolating tape to avoid getting water and moisture to the copper wire of the lamp which can damage electronic components. When it comes to lamp and plug, the plug should be mounted safely.
- Do not cut off tinned ends.
- Lamps must be installed only in accordance with UNECE regulations.



www.myKAMAR.com

PHOTO AND TECHNICAL DRAWING:

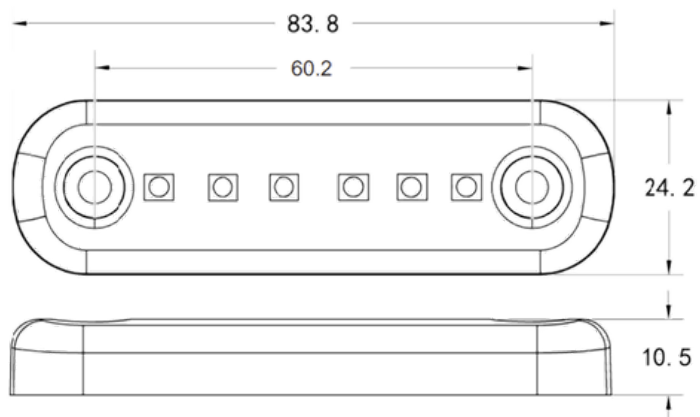

TECHNICAL SPECIFICATIONS:

MATERIAL	LED QUANTITY	MOUNTING	WIRE	FUNCTION	WATT	VOLTAGE	CERTIFICATES	PACKING/ WEIGHT
» Lens: PC » Housing: PC	» 6	» screws	» 25m	» Rear position lamp	» 1W	» 12V/24V	» ECE R10 » ECE R148 » IP 67	» carton dimension: 42x27x28cm » weight: 6,2 kg » 100 pcs/bulk box



We reserve the right to change technical data and any errors. Photos and specifications are for reference only, and the actual product may vary slightly. Reproduction in whole or parts of the catalog without written authorization is prohibited.